

Level Measurement Expert

Guided Wave Radar Level Transmitter

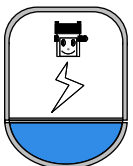
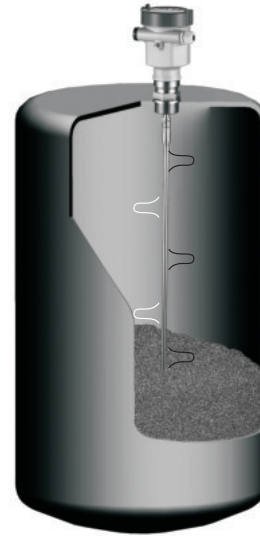

Table of Contents

1	Measurement Principle.	1
2	Product Overview	2
3	Mounting Requirement.	5
4	Electrical Connection.	7
5	Adjustment Instructions.	10
6	Dimensional Drawings.	13
7	Technical Specifications.	17
8	Selection & Ordering Information Application.	20
9	Questionnaire.	26

1. Measurement Principle



- Principle

High frequency microwave pulses travels along the detecting component (steel rope or rod) and reflects when veaching the product surface. The time from emission to reception is proportional to the distance between the surface and the reference plane on the instrument.

- Features

TNRF5X equipped with the advanced microprocessor and unique EchoDiscovery echo processing technology can be used in severe ambience.

TNRF5X with extremely low emission power, can be mounted on various metal or nonmetal vessels, harmless towards the environment and human beings.

There are multiple options availabe in choosing various process connection and detectting component, which enables TNRF5X to be applied in a broad extent of applications, such as high temperature, high pressure, medium with small dielectric constant and etc.

2 Product Overview

TNRF51



TNRF52



Application:	Level measurement for liquids/solids, in severe ambience
Max. Measurement Range:	Rope: 30m / Rod: 6m
Measurement Accuracy:	±10mm
Process Connection:	G1½A, G2A, 1½NPT
Detection Component	
Material:	Stainless Steel 316L/PTFE
Process Pressure:	(-0.1 ~ 4) MPa
Process Temperature:	(-40 ~ 150) °C
Signal Output:	(4 ~ 20) mA / HART
Power:	2-Wire (DC24V) 4-Wire (DC24V / AC220V)

Application:	Level measurement for liquids/solids, in severe ambience
Max. Measurement Range:	6m
Measurement Accuracy:	±10mm
Process Connection:	PTFE flange
Detection Component	
Material:	PTFE
Process Pressure:	(-0.1 ~ 1.6) MPa
Process Temperature:	(-40 ~ 150) °C
Signal Output:	(4 ~ 20) mA / HART
Power:	2-Wire (DC24V) 4-Wire (DC24V / AC220V)

TNRF53



TNRF55



Application: Level measurement for liquids, especially for ones with small dielectric constant, in severe ambience

Max. Measurement Range: 6m

Measurement Accuracy: $\pm 10\text{mm}$

Process Connection: G1½A、G2A

Detection Component

Material: Stainless Steel 316L/PTFE

Process Pressure: (-0.1~4) MPa

Process Temperature: (-40~150) °C

Signal Output: (4~20)mA/HART

Power: 2-wire (DC24V)
4-wire (DC24V/AC220V)

Application: Level measurement for liquids in severe ambience with high temperature/pressure

Max. Measurement Range: Rope:30m/Rod:6m

Measurement Accuracy: $\pm 10\text{mm}$

Process Connection: G1½A/G2A/1½NPT

Detection Component

Material: Stainless Steel 316L/Chinaware

Process Pressure: (-0.1~4) MPa

Process Temperature: (-40~200) °C

Signal Output: (4~20)mA/HART

Power: 2-wire (DC24V)
4-wire (DC24V/AC220V)

TNRF55



TNRF56



Application: Level measurement for liquids, especially in severe ambience with very high temperature and pressure

Max. Measurement Range: Rope:30m/Rod:6m

Measurement Accuracy: $\pm 10\text{mm}$

Process Connection: G1½A/G2A/1½NPT

Detection Component

Material: Stainless Steel 316L/Chinaaware

Process Pressure: (Vacuum~40) MPa

Process Temperature: (-200~400) °C

Signal Output: (4~20)mA/HART

Power: 2-Wire (DC24V)
4-Wire (DC24V/AC220V)

Application: Level measurement for liquids with small dielectric constant or powder

Max. Measurement Range: Rope:30m/Rod:6m

Measurement Accuracy: $\pm 10\text{mm}$

Process Connection: G1½A/G2A/1½NPT

Detection Component

Material: Stainless Steel 316L/PTFE

Process Pressure: (-0.1~4) MPa

Process Temperature: (-40~150) °C

Signal Output: (4~20)mA/HART

Power: 2-Wire (DC24V)
4-Wire (DC24V/AC220V)

3. Mounting Requirement

- Basic Requirement

Keep in mind that the rope/rod is kept away from obstructions within vessel. The obstructions are like : ladders, limit switches, heating spirals, struts and etc. Furthermore, rope or rods must not intersect the filling streams.

Be cautious during the installation: the level of the measured medium must not be in the blanking zone, the mounting location must keep a min distance to the vessel wall, the rope or rod is perpendicular to the surface of the measured medium. Local or federal safety instruction must be abided when installation is in explosion hazardous area. Aluminium housing is used for intrinsically safe version, which can be used in explosion hazardous areas. The instrument must be connected to ground potential in this situation.

- Illustrations

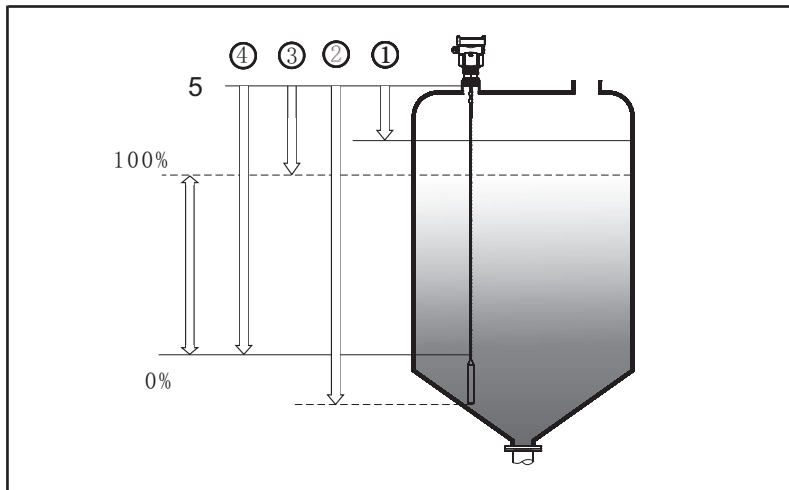

The reference plane is the thread or flange surface

- 1 Blanking Zone (Menu 1. 10)
- 2 Length (Menu1. 9)
- 3 Max. Measurement Range (Menu1. 2)
- 4 Min. Measurement Range (Menu 1. 1)
- 5 reference plane

Note: The level of the measured medium must not be in either blanking zone.

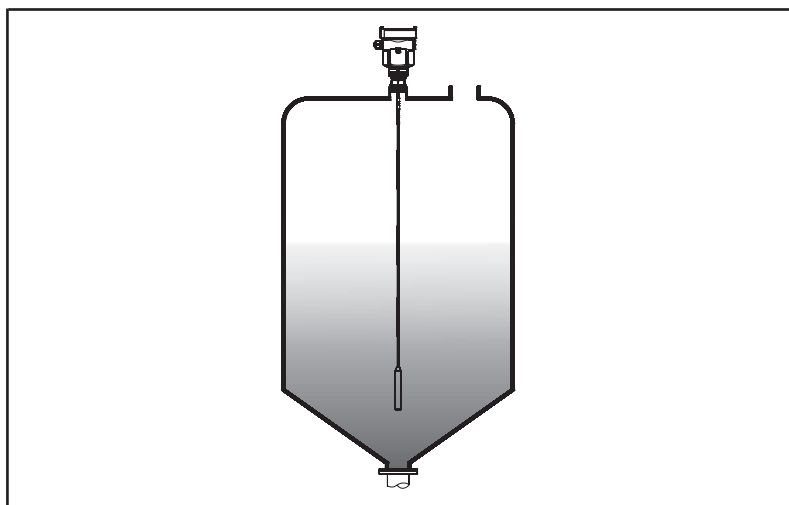

The best mounting location for a conical vessel with flat top is the center of the vessel's top, as the effective measurement can reach the bottom of vessel.

- Socket

Container Extension

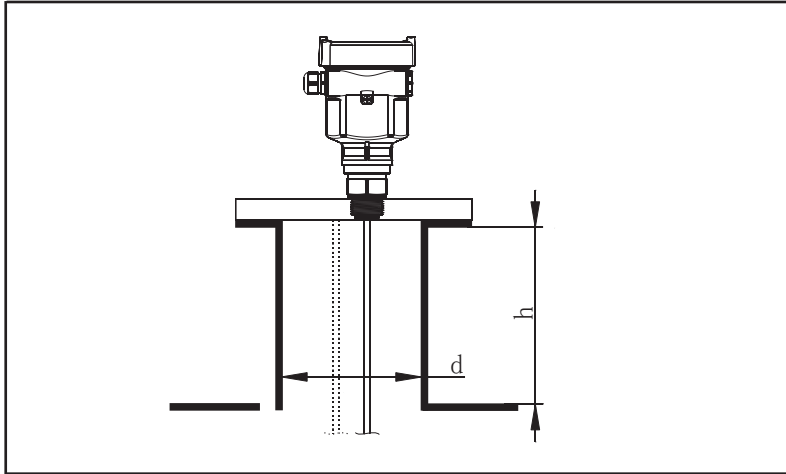

Avoid installation with socket if possible, otherwise try to minimize the length of socket. In case of long socket, small vessel or medium with low dielectric constant, you are advised to use TNRF56.

- Rights and Wrongs in Mounting

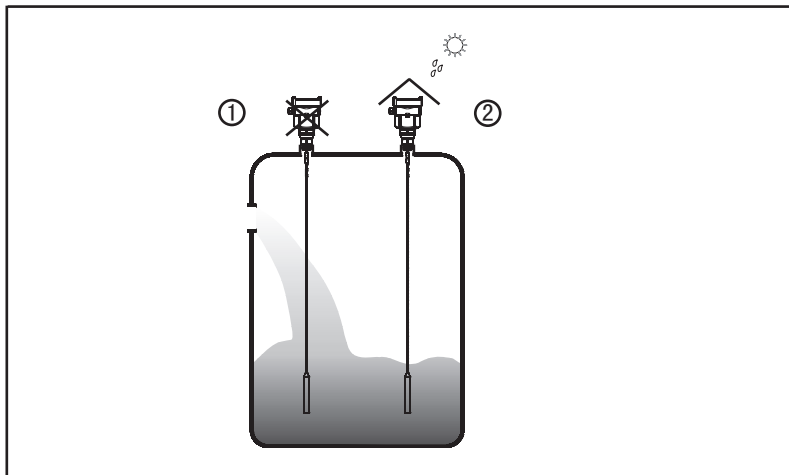

1 Wrong: The rod/rope is in/above filling stream, which results in the measurement of filling stream not the target medium.

2 Correct

Note: Sun shield or rain-proof is required for outdoor mounting.

- Damp-proof

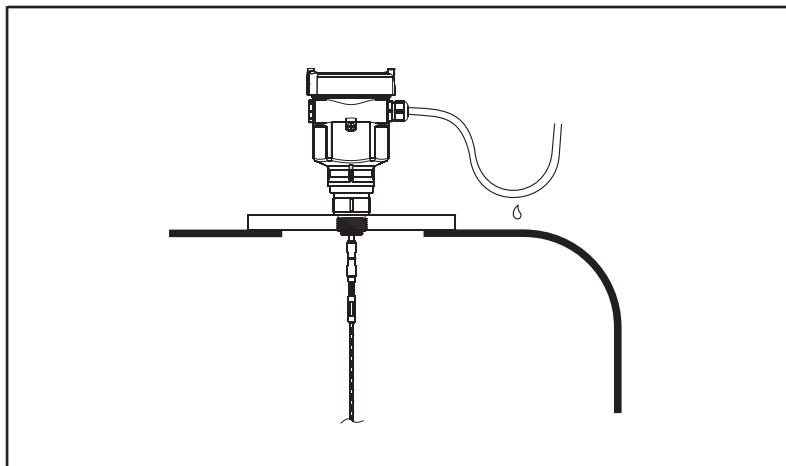

When mounting outdoors, humid indoors or on cooling/heating vessels, in order to avoid damp seal rings used on cables should be screwed tight, and the cable must be bended downward outside cable entry, as indicated on the diagram below:

4 Electrical Connection

- Power Supply

20mA/HART(2-Wire) Power supply and current signal are carried by the same two-wire connection cable. See the Technical Specifications of this guide for detailed requirement on power supply. A safety barrier should be placed between power supply and instrument for intrinsically safe version.

20mA/HART(4-wire) Power supply and current signal are carried by two 2-wire connection cables respectively. See the Technical Specifications of this guide for detailed requirement on power supply. Earth-connected current output can be used for standard version of level instruments, while the explosion proof version must be operated with a floating current output. Both instruments and earth terminals should be connected with ground firmly and securely. Normally you can either choose to connect with the earth terminal on vessel or adjacent ground in case of plastic vessels.

- Cable Connection

General Introduction

Standard 2-wire cable with outside diameter of 5...9mm, which assures the seal effect of cable entry, can be used as feeder cable. You are recommended to use screened cables in the event of electromagnetic Connection cable with special earth wire can be used as feeder cable.

4~20mA/HART

Connection cable with special earth wire can be used as feeder cable.

20mA/HART(4-wire)

The two ends of shielded cable must be connected with earth terminal. The shielded cable must be connected with inner earth terminal directly inside the transducer, while the outside earth terminal on housing must be connected with ground.

Shielding & Grounding

earth-connected current, the shielding side of shielded cable must be connected to ground potential via a ceramic capacitor (e.g. : 1 μ F 1500V) in order to dampen the low frequency grounding current and avoid the disturbance caused by high frequency signals

- Wiring Diagram

2-wire

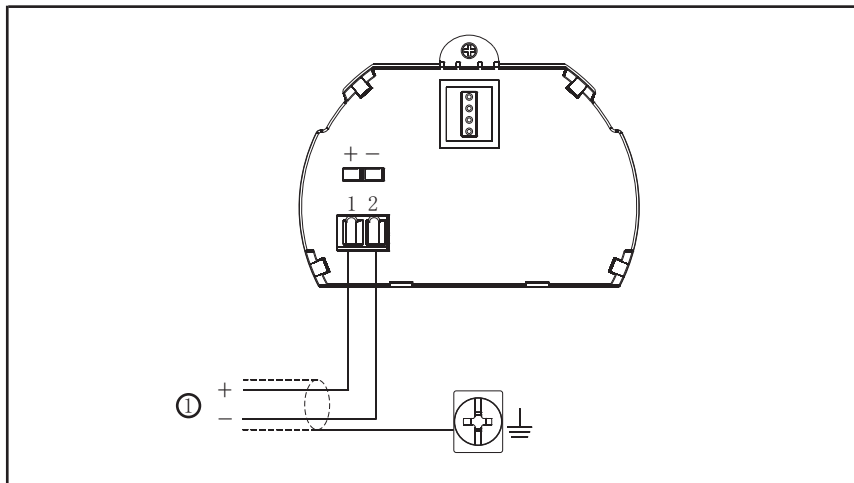

2-wire wiring used for HART (electronic unit B)

1) Power Supply and Signal Output

4-wire/2-chamber

Wiring Diagram: 220V AC Power Supply, 4...20mA Signal Output (electronic unit D)

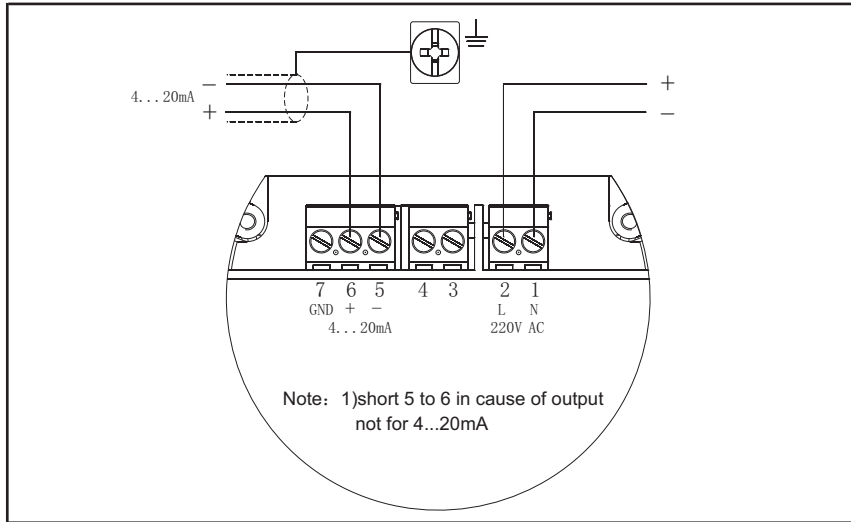

Wiring Diagram: 4-wire 24V DC Power Supply, 4...20mA Signal Output (electronic unit C)

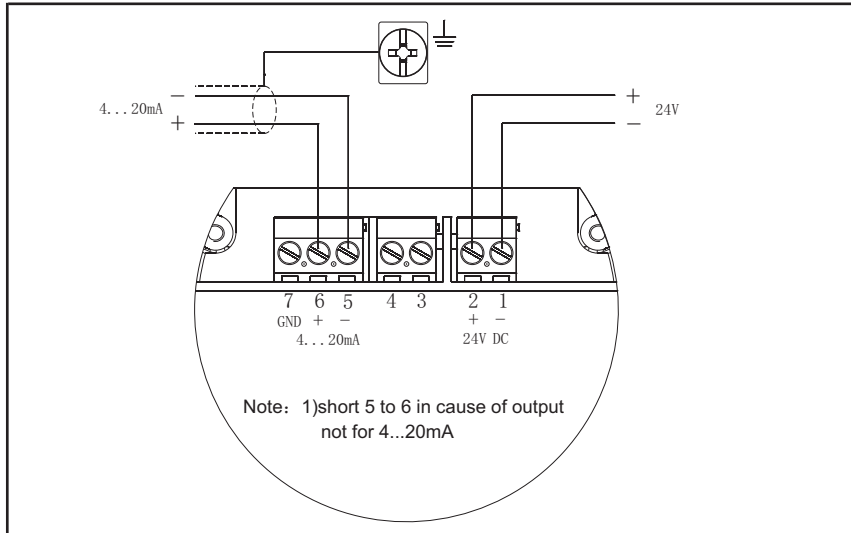

Wiring Diagram: dual-wire 24V DC Power Supply, 4...20mA Signal Output (electronic unit E)

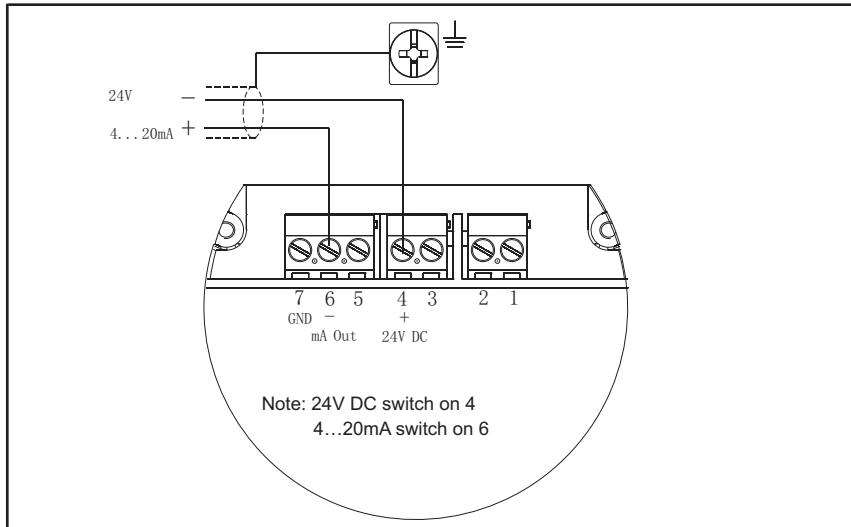

● Explosion Proof Connection

The intrinsic safety version sensors (Exia II c T6) use Alu-die casting housing and filling silicone rubber encapsulants internal structure aimed to prevent sparks resulted from circuit failure from leaking out. It is applicable for the continuous level measurement of flammable medium under Exia II c T6.

A safety barrier FBS-2 must be used together with the intrinsic safety instrument. It is an associated device to this product for the power supply of this product. the main specification is intrinsic safety: Exia II C, voltage of power supply: 24V DC+5%, short-circuit current: 135mA, operating current: 4...20mA.

All cables must be shielded. The max length is 500m for the cable from the barrier to the sensor. Stray capacitor $\leq 0.1 \mu F/Km$, stray inductance $\leq 1mH/Km$. Instrument must be connected to the ground potential. Any unapproved associated device is not allowed to be used.

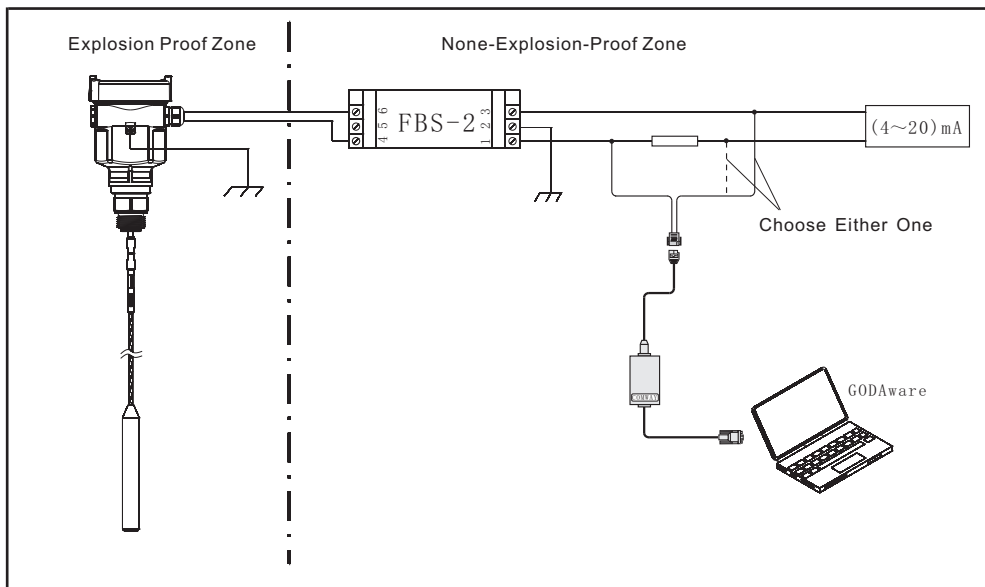

Adjustment with GODAware

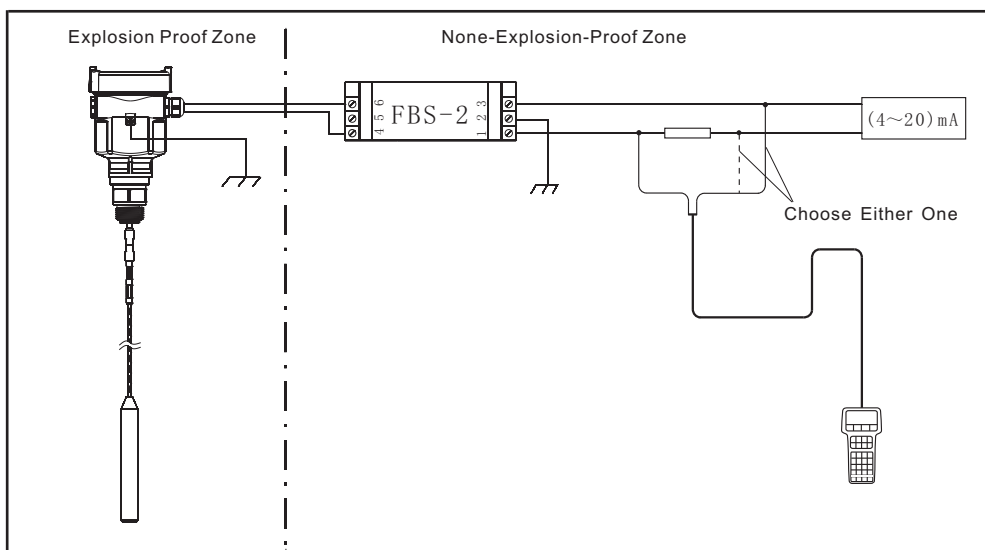

Adjustment with HART Handheld Programmer

5 Adjustment Instructions

● Adjustment Methods

- Three methods are available for TNRF5X adjustment: 1 Display/adjustment module ViewPoint
2 An adjustment software-GODAware
3 HART handheld programmer

ViewPoint is a pluggable display/adjustment module. The adjustment can be done through operating with four buttons on ViewPoint. Optional menu operation languages are available for selection. ViewPoint is only used for display after adjustment in that the measurement results can be seen clearly through the glass window.

Display/Adjustment Module

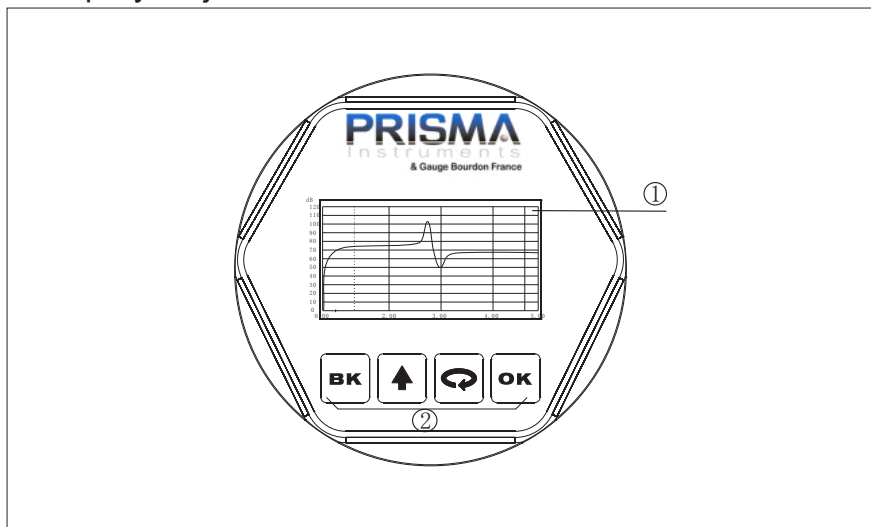

1 LCD 2 Adjustment Keypad

[OK]Keypad

- Enter programming mode;
- Confirm programming options;
- Confirm modifications to parameters.

[↻]Keypad

- Choose programming options;
- Choose the digit of parameters to edit;
- Display the contents of parameters.

[↑]Keypad

- Modify parameter values.

[BK]Keypad

- Programming mode exit;
- Return to higher menu level.

Shortcut

- [BK]Display Echo wave

PRISMAware

Connect with another unit through HART.

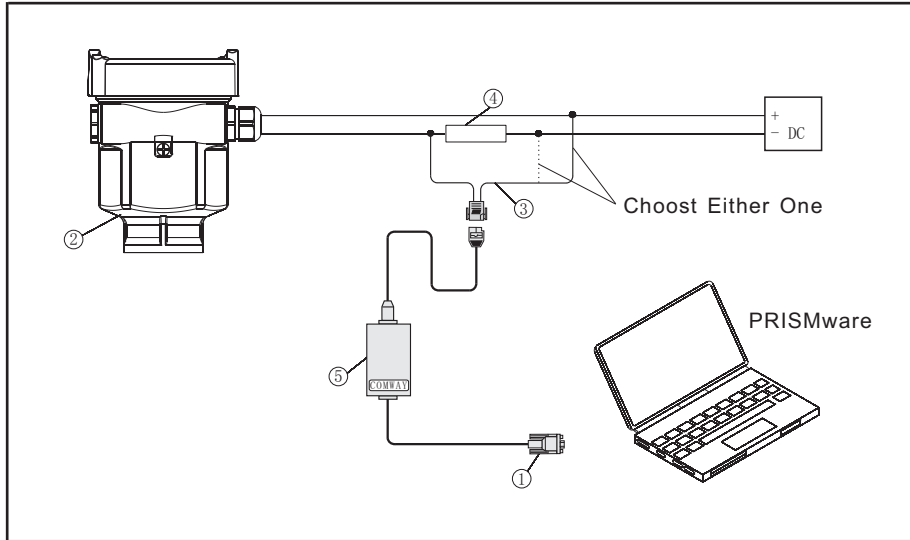

- 1 RS232 Connect Cable/USB port
- 2 TNRF5X
- 3 HATR port adapter used on COMWAY convertor
- 4 250 ohm Resistance
- 5 COMWAY Convertor

Connect with another unit through I²C.

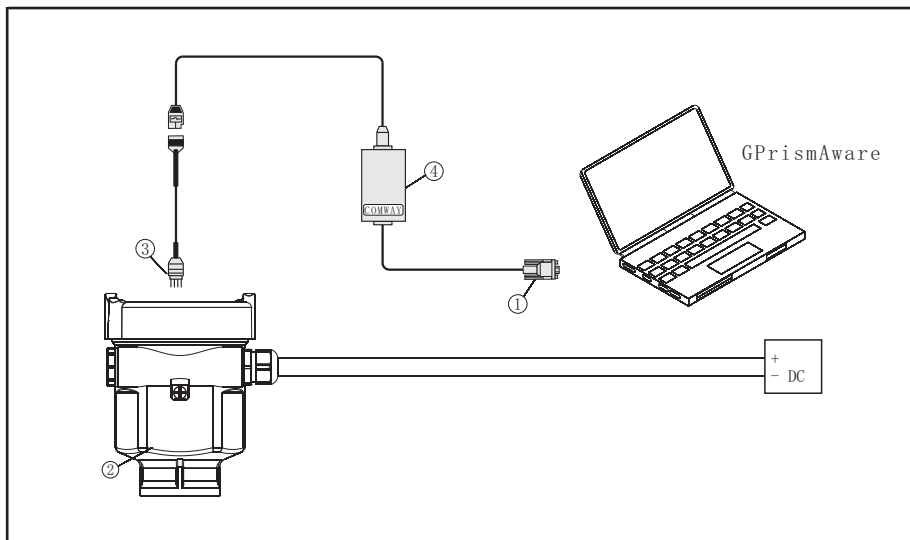

- 1 RS232 Connect Cable/USB port
- 2 GDRD5X
- 3 I²C adapter port used on MOMWAY convertor
- 4 COMWAY Convertor

HART Handheld Programmer

Adjust GDRD5X with HART Handheld Programmer

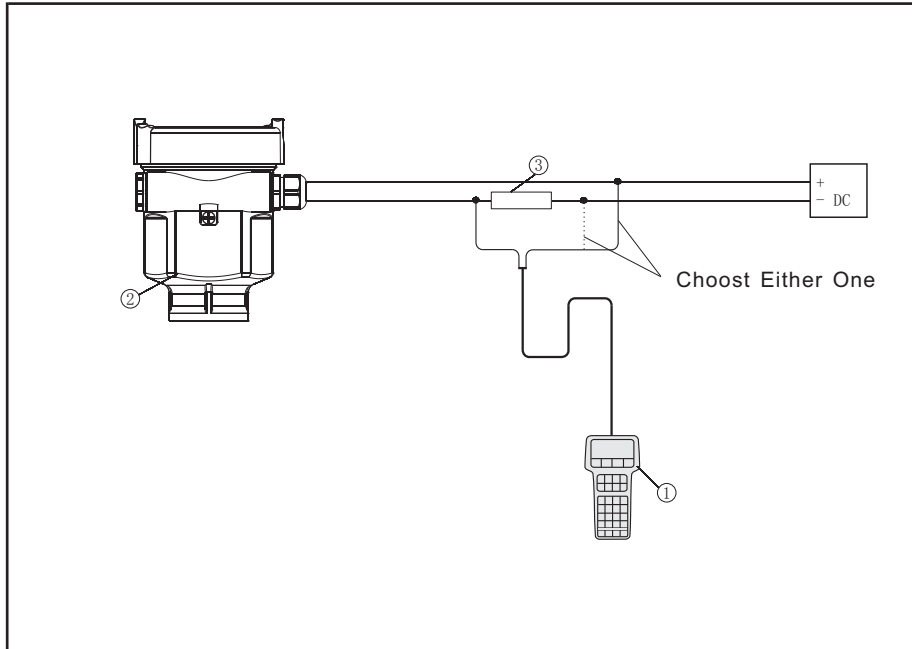

- 1 HART Handheld Programmer
- 2 GDRD5X
- 3 250 ohm Resistance

6 Dimension (Unit: mm)

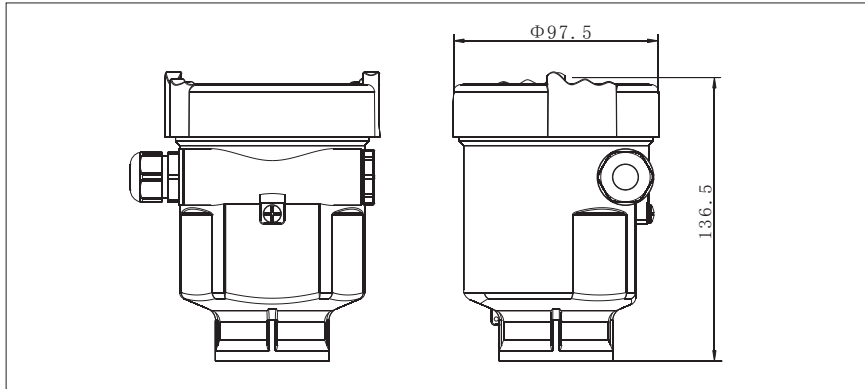

Housing A/B/G
Material: PBT/AL/316L

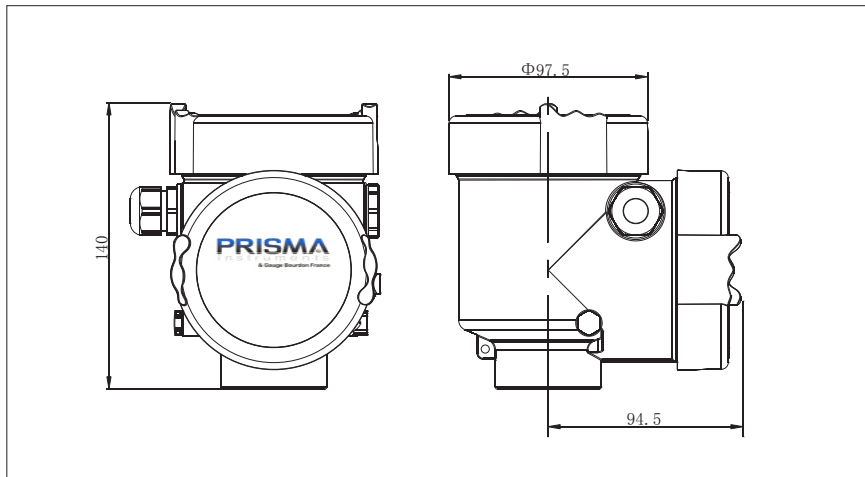

Housing D/H
two-chamber
Material: AL/316L

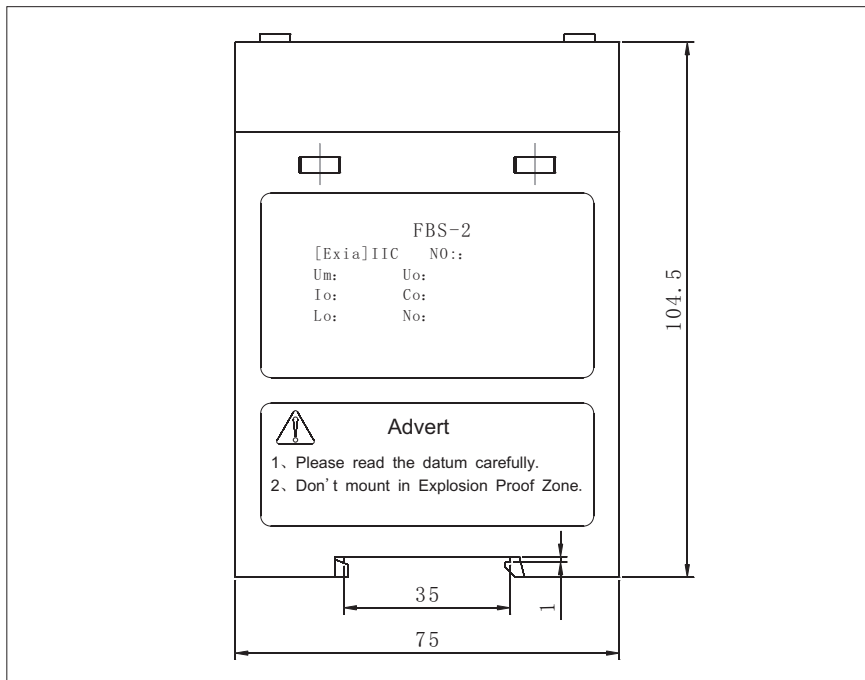

FBS Series

TNRF51

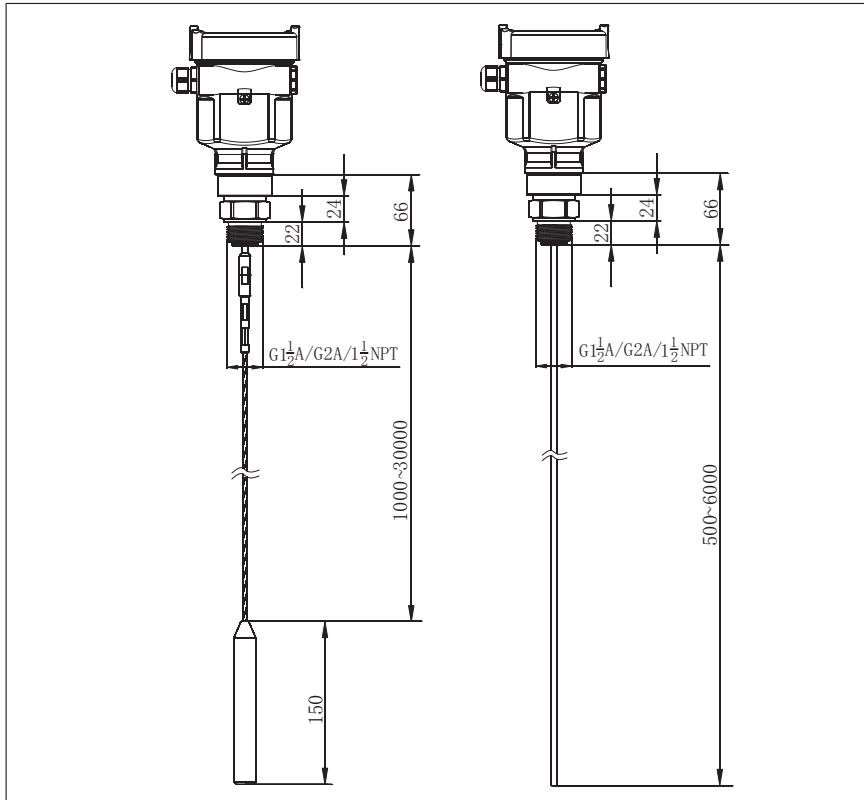

TNRF52

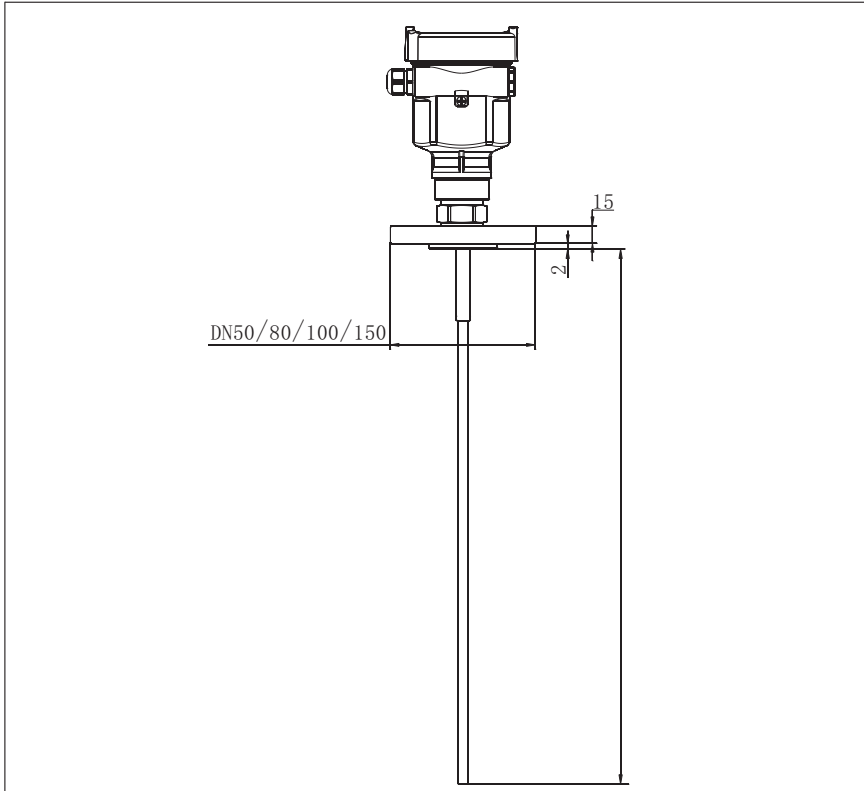

TNRF53

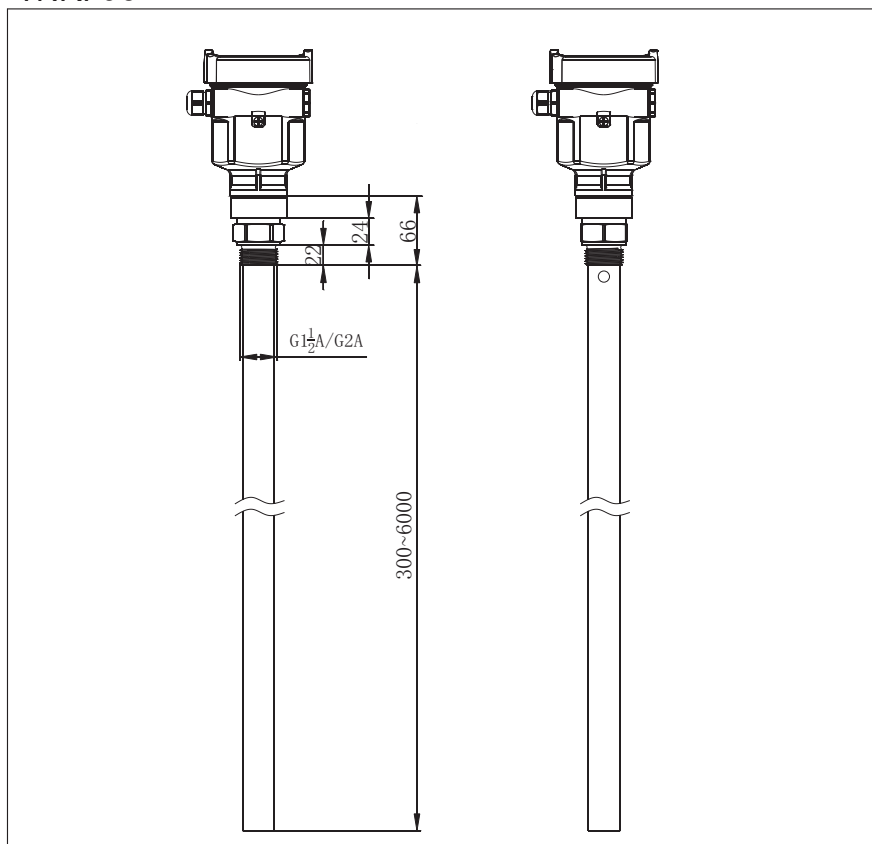

TNRF54

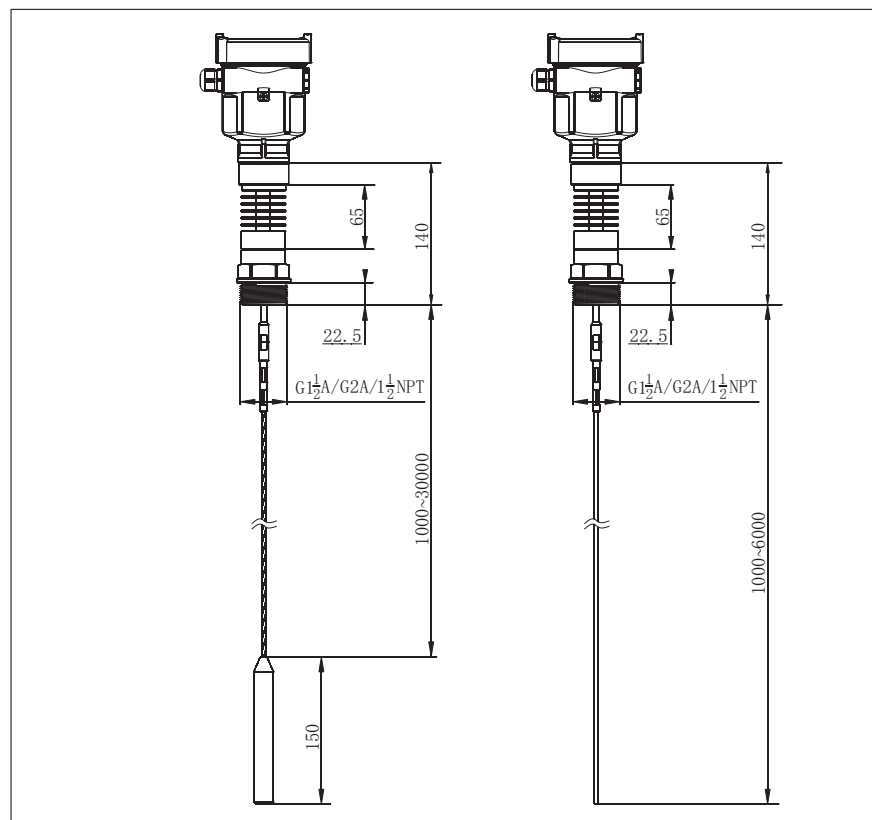

TNRF55

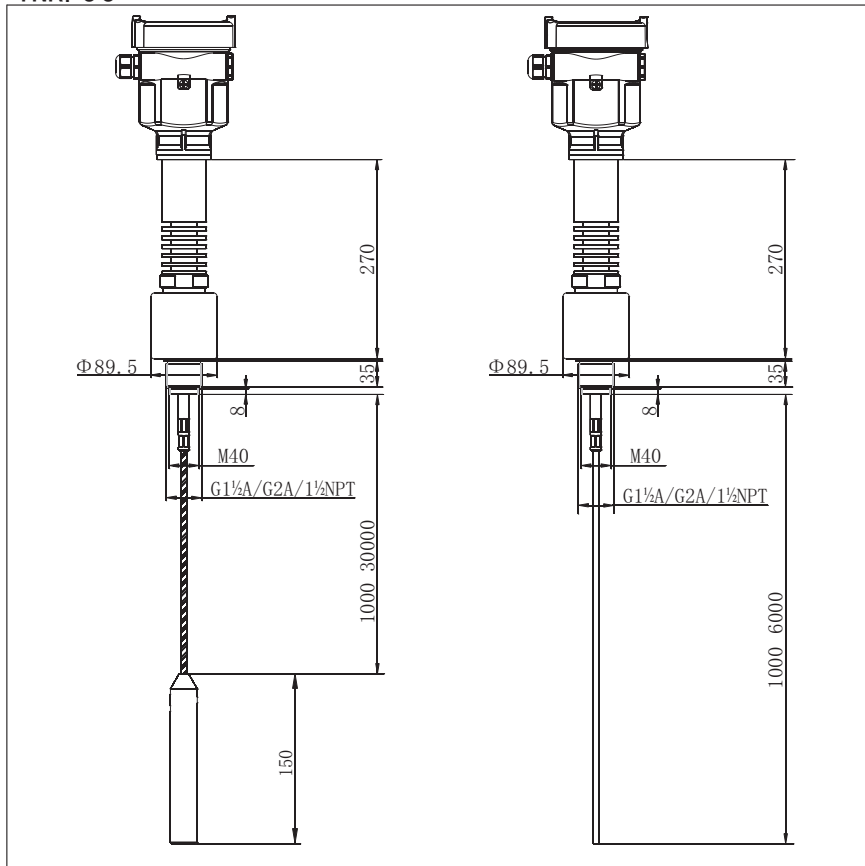

TNRF56

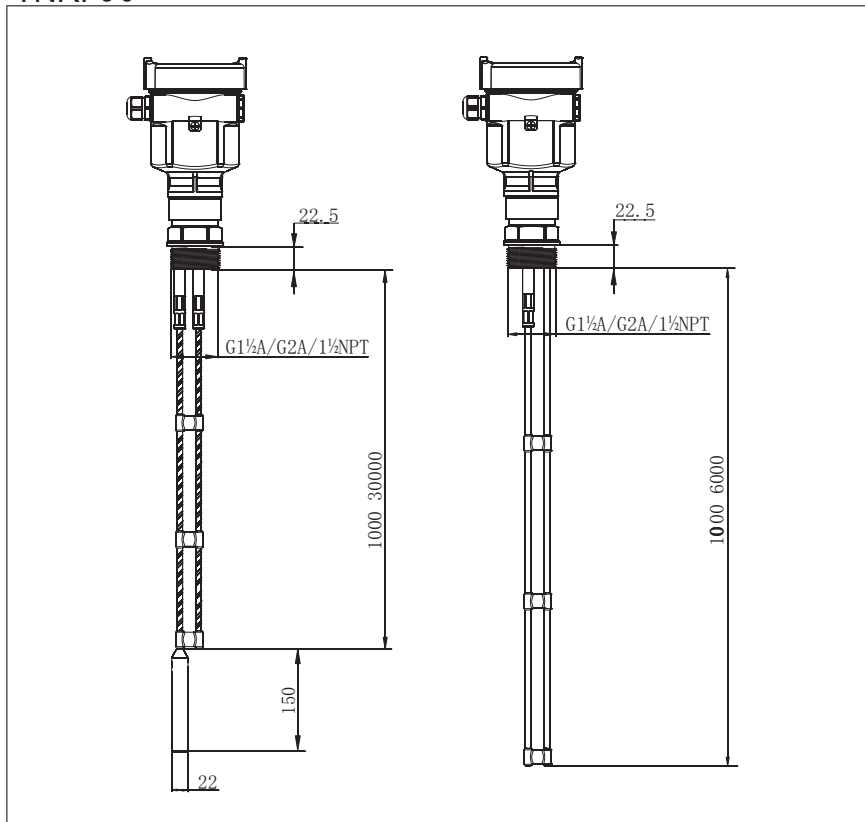

● General Parameters	Probe Material:	
	-Rod	Stainless Steel316L/PTFE
	-Cable	Stainless Steel316L/PTFE/ceramic
	-Coax	Stainless Steel316L/PTFE
	-Seal	Viton fluoroelastomer, Kalrez perfluoroelastomer
	-Process Connection	Stainless Steel316L
	-Housing	Stainless Steel316L Alu-die casting, Powder Coated,
	-Seal ring between housing and housing cover	Silicone rubber
	-ViewPoint window	Polycarbonate
	-Ground terminal	Stainless Steel316L

Weight

-TNRF51	9kg	(Depends on process connections and housing)
-TNRF52	5.5kg	(Depends on process connections and housing)
-TNRF53	6kg	(Depends on process connections and housing)
-TNRF54	12kg	(Depends on process connections and housing)
-TNRF55	9kg	(Depends on process connections and housing)
-TNRF56	9kg	(Depends on process connections and housing)

Power

2-Wire

-Standard Version	16. . . 26V DC
Intrinsic Safe Version	(21. 6~26. 4) V DC
Power consumption	max.22.5mA
Ripple Allowed	
-<100Hz	U _{ss} <1V
-<100Hz. . . 10KHz	

4-wire/2-chamber

Intrinsic Safe+Explosion-Proof	(22. 8~26. 4) V DC, (198~242) V AC
Power Consumption	max.1VA, 1W

Cable Entry/Plug	One cable entry of M20X1. 5 (cable diameter of 5. . . 9m) , one blind stopper M20X1. 5
Spring Connection Terminal	Applicable for cables with cross section of 2. 5mm

Parameters on Cable

Output

Output Signal	4. . . 20mA/HART
Resolution	1.6 μ A
Failure mode	20. 5mA, 22mA, hold
-2-wire load resistance	See the diagram below
-4-wire load resistance	Max.500ohm
Integration Time	0. . . 40sec, adjustable

2-Wire Load Resistance Diagram

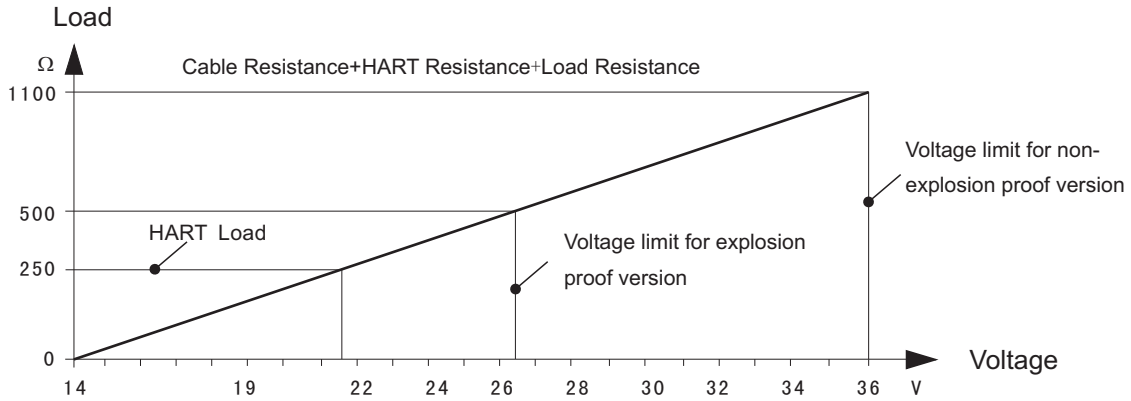

Technical data

Max Measurement Distance

-TNRF51	30m/6m (Rope/Rod)
-TNRF52	6m
-TNRF53	6m
-TNRF54	30m/6m
-TNRF55	30m/6m
-TNRF55	30m/6m

Measurement Interval

About 1sec (Depend on parameter settings)

Adjustment Time¹⁾

About 1sec (Depend on parameter settings)

Resolution of Display

1mm

Accuracy

See the accuracy illustration diagram below

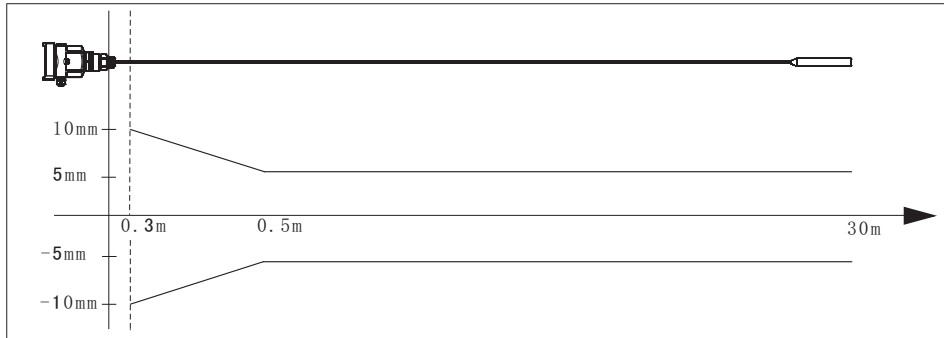

Temperature for Storage/Transport

-40...+80°C

Process Temperature (Probe)

-TNRF51, TNRF52, TNRF53, TNRF56 -40...+150°C

-TNRF54 -40...+200°C

-TNRF55 -200...+400°C

-Relative Humidity <95%

-Pressure Max.400bar

Vibration Proof Mechanical vibration 10m/s², 10...150Hz

Max Pulling Force See the illustrative diagram on pulling force

Max Pulling Force or Lateral Load

1) The generation of accurate measurement results needs longer time than usual in the event of drastic level changes(mx. Error 10%).

When measuring solid medium, the pulling force is determined by the diameter of vessel and medium level, some examples of pulling force generated by typical medium are shown on the diagrams below.

TNRF51

Metal vessel with smooth sidewall
 - - - - - Diameter: 12m
 - . - . - Diameter: 9m
 Diameter: 6m
 _____ Diameter: 3m

Grain

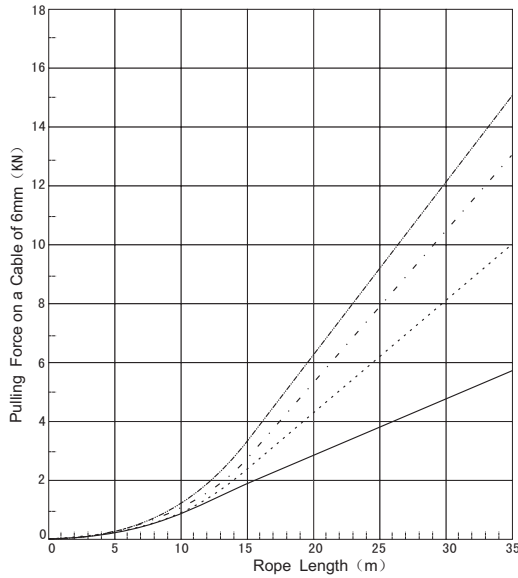

Sand

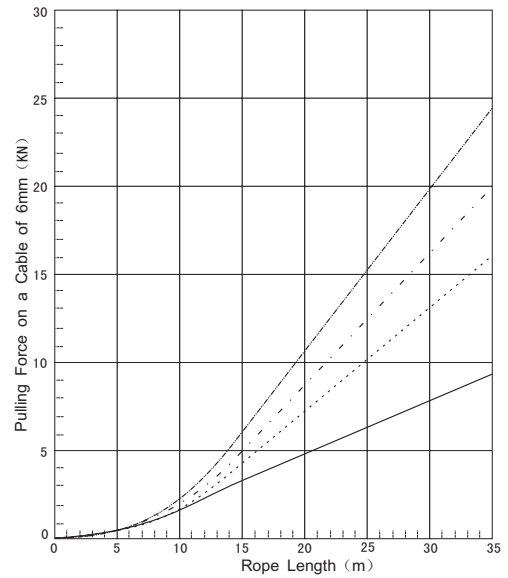

Plastic Particle

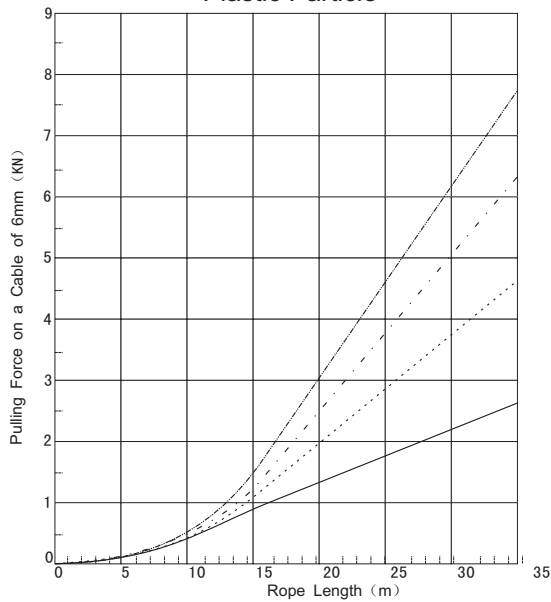

Cement

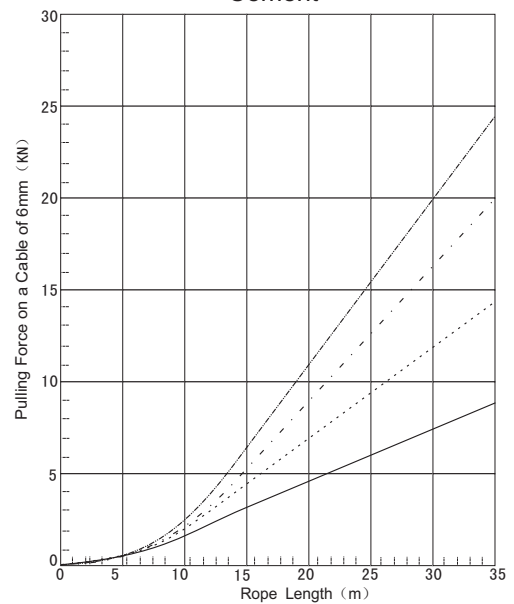

8 Selection & Ordering Information

● TNRF51

Explosion Proof Approval	
P	Standard (Without Approval)
I	Intrinsically Safe (Exia IIC T6)
C	Intrinsically Safe+Ship Approval (Exia IIC T6)
G	Intrinsically Safe+Explosion proof (Exd ia IIC T6)
Type of detecting component/Material	
A	Rope/Φ6mm/Stainless Steel316L/PTFE
B	Rope/Φ10mm/Stainless Steel316L/PTFE
C	Lengthen PP/Rope/Stainless Steel 316L
D	Lengthen PP/Rod/Stainless Steel 316L
E	Lengthen PTFE/Rope/Stainless Steel 316L
F	Lengthen PTFE/Rod/Stainless Steel 316L
X	Special Design
Seal/Process Temperature	
GP	Thread G1½A
KP	Thread G2A
NP	Thread 1½NPT
YP	Special Design
Seal/Process Temperature	
A	Viton / (-30~150) °C
B	Kalrez/ (-40~150)°C
Electronic	
B	(4~20)mA/HART 2-wire
C	(4~20)mA/(22.8~26.4)V DC /HART 4-wire
D	(198~242)V AC/HART 4-wire
E	(4~20)mA/(22.8~26.4)V DC /HART 2-wire
X	Special Design
Housing/Protection	
A	Aluminium/IP67
B	Plastic/IP66
D	Aluminium (2-chamber)/IP67
G	Stainless Steel316L/IP66
H	Stainless Steel316L(2-chamber)/IP67
Cable Entry	
M	M20x1.5
N	½NPT
Display/Programming	
A	Yes
X	No
Rope/rod length	
5-digit number (unit:mm)	

Note: The instrument with approval "I" can use Electronic "B" and housing "A, D, G, H",
The instrument with approval "C" can use Electronic "B" and housing "G",
The instrument with approval "G" can use Electronic "C or D, E" and housing "D, H".
Standard flange size of the reference GB/T9119-2000 Thickness of 15mm.

● TNRF52

Explosion Proof Approval	
P	Standard (Without Approval)
I	Intrinsically Safe (Exia IIC T6)
C	Intrinsically Safe+Ship Approval (Exia IIC T6) (NO)
G	Intrinsically Safe+Explosion proof (Exd ia IIC T6)
Type of detecting component/Material	
A	Rod/Φ6mm/Stainless Steel 316L
Process Connection/Material	
GP	flange DN50 PN1.6 Stainless Steel 316L (GB/T9119-2000)
NP	flange DN80 PN1.6 Stainless Steel 316L (GB/T9119-2000)
EP	flange DN100 PN1.6 Stainless Steel 316L (GB/T9119-2000)
FP	flange DN150 PN1.6 Stainless Steel 316L (GB/T9119-2000)
YP	Special Design
Seal/Process Temperature	
A	(-40~150) °C
Electronic	
B	(4~20)mA/HART 2-wire
C	(4~20)mA/(22.8~26.4)V DC /HART 4-wire
D	(198~242)V AC/HART 4-wire
E	(4~20)mA/(22.8~26.4)V DC /HART 2-wire
X	Special Design
Housing/Protection	
A	Aluminium/IP67
B	Plastic/IP67
D	Aluminium (2-chamber)/IP67
G	Stainless Steel316L/IP67
H	Stainless Steel316L(2-chamber)/IP67
Cable Entry	
M	M20x1.5
N	½NPT
Display/Programming	
A	Yes
X	No
Rope/rod length	
5-digit number (unit:mm)	

Note: The instrument with approval "I" can use Electronic "B" and housing "A, D, G, H",
 The instrument with approval "G" can use Electronic "C or D, E" and housing "D, H".
 Standard flange size of the reference GB/T9119-2000 Thickness of 15mm.

● TNRF53

Explosion Proof Approval	
P	Standard (Without Approval)
I	Intrinsically Safe (Exia IIC T6)
C	Intrinsically Safe+Ship Approval (Exia IIC T6) (NO)
G	Intrinsically Safe+Explosion proof (Exd ia IIC T6)
Type of detecting component/Material	
A	Coax/Stainless Steel316L
Process Connection/Material	
GP	Thread G1½A
KP	Thread G2A
NP	Thread 1½NPT
YP	Special Design
Seal/Process Temperature	
A	Viton/ (-30~150)°C
B	Kalrez/ (-40~150) °C
Electronic	
B	(4~20) mA/HART 2-wire
C	(4~20) mA/(22.8~26.4) V DC /HART 4-wire
D	(198~242) V AC/HART 4-wire
E	(4~20) mA/(22.8~26.4) V DC /HART 2-wire
X	Special Design
Housing/Protection	
A	Aluminium/IP67
B	Plastic/IP67
D	Aluminium (2-chamber)/IP67
G	Stainless Steel316L/IP67
H	Stainless Steel316L(2-chamber)/IP67
Cable Entry	
M	M20x1.5
N	½NPT
Display/Programming	
A	Yes
X	No
Rope/rod length	
5-digit number (unit:mm)	

Note: The instrument with approval "I" can use Electronic "B" and housing "A, D, G, H",
The instrument with approval "G" can use Electronic "C or D, E" and housing "D, H".
Standard flange size of the reference GB/T9119-2000 Thickness of 15mm.

● TNRF54

Explosion Proof Approval	
P	Standard (Without Approval)
I	Intrinsically Safe (Exia IIC T6)
C	Intrinsically Safe+Ship Approval (Exia IIC T6) (NO)
G	Intrinsically Safe+Explosion proof (Exd ia IIC T6)
Type of detecting component/Material/Process Temperature	
A	Rope/Stainless Steel 316L/PTFE
B	Rod/Stainless Steel 316L/PTFE
C	Lengthen PP/Rope/Stainless Steel 316L
D	Lengthen PP/Rod/Stainless Steel 316L
E	Lengthen PTFE/Rope/Stainless Steel 316L
F	Lengthen PTFE/Rod/Stainless Steel 316L
X	Special Design
Process Connection/Material	
GP	Thread G1½A
KP	Thread G2A
NP	Thread 1½NPT
YP	Special Design
Seal/Process Temperature	
A	Viton/ (-30~150)°C
B	Kalrez/ (-40~150) °C
Electronic	
B	(4~20)mA/HART 2-wire
C	(4~20)mA/(22.8~26.4)V DC /HART 4-wire
D	(198~242)V AC/HART 4-wire
E	(4~20)mA/(22.8~26.4)V DC /HART 2-wire
X	Special Design
Housing/Protection	
A	Aluminium/IP67
B	Plastic/IP67
D	Aluminium (2-chamber)/IP67
G	Stainless Steel316L/IP67
H	Stainless Steel316L(2-chamber)/IP67
Cable Entry	
M	M20x1.5
N	½NPT
Display/Programming	
A	Yes
X	No
Rope/rod length	
5-digit number (unit:mm)	

Note: The instrument with approval "I" can use Electronic "B" and housing "A, D, G, H",
The instrument with approval "G" can use Electronic "C or D, E" and housing "D, H".
Standard flange size of the reference GB/T9119-2000 Thickness of 15mm.

● TNRF55

Explosion Proof Approval	
P	Standard (Without Approval)
I	Intrinsically Safe (Exia IIC T6)
C	Intrinsically Safe+Ship Approval (Exia IIC T6) (NO)
G	Intrinsically Safe+Explosion proof (Exd ia IIC T6)
Type of detecting component/Material	
A	Rope/Stainless Steel316L/Ceramic
B	Rod/Stainless Steel316L/Ceramic
Process Connection/Material	
GP	Thread G1½A
KP	Thread G2A
NP	Thread 1½NPT
YP	Special Design
Electronic	
B	(4~20) mA/HART 2-wire
C	(4~20) mA/(22.8~26.4) V DC /HART 4-wire
D	(198~242) V AC/HART 4-wire
E	(4~20) mA/(22.8~26.4) V DC /HART 2-wire
X	Special Design
Housing/Protection	
A	Aluminium/IP67
B	Plastic/IP67
D	Aluminium (2-chamber)/IP67
G	Stainless Steel316L/IP67
H	Stainless Steel316L(2-chamber)/IP67
Process Temperature	
A	(-200~400) °C/ (Vacuum~4) MPa
B	(-200~400) °C/ (Vacuum~40) MPa
Cable Entry	
M	M20x1.5
N	½NPT
Display/Programming	
A	Yes
X	No
Rope/rod length	
5-digit number (unit:mm)	

Note: The instrument with approval "I" can use Electronic "B" and housing "A, D, G, H",
The instrument with approval "G" can use Electronic "C or D, E" and housing "D, H".
Standard flange size of the reference GB/T9119-2000 Thickness of 15mm.

● TNRF56

Explosion Proof Approval	
P	Standard (Without Approval)
I	Intrinsically Safe (Exia IIC T6)
C	Intrinsically Safe+Ship Approval (Exia IIC T6) (NO)
G	Intrinsically Safe+Explosion proof (Exd ia IIC T6)
Type of detecting component/Material	
A	Rope/Stainless Steel 316L/PTFE
B	Rod/Stainless Steel 316L/PTFE
Process Connection/Material	
GP	Thread G1½A
KP	Thread G2A
NP	Thread 1½NPT
YP	Special Design
Electronic	
B	(4~20) mA/HART 2-wire
C	(4~20) mA/(22.8~26.4) V DC /HART 4-wire
D	(198~242) V AC/HART 4-wire
E	(4~20) mA/(22.8~26.4) V DC /HART 2-wire
X	Special Design
Housing/Protection	
A	Aluminium/IP67
B	Plastic/IP67
D	Aluminium (2-chamber)/IP67
G	Stainless Steel316L/IP67
H	Stainless Steel316L(2-chamber)/IP67
Process Temperature	
A	(-200~400) °C/ (Vacuum~4) MPa
B	(-200~400) °C/ (Vacuum~40) MPa
Cable Entry	
M	M20x1.5
N	½NPT
Display/Programming	
A	Yes
X	No
Rope/rod length	
5-digit number (unit:mm)	

Note: The instrument with approval "I" can use Electronic "B" and housing "A, D, G, H",
The instrument with approval "G" can use Electronic "C or D, E" and housing "D, H".
Standard flange size of the reference GB/T9119-2000 Thickness of 15mm.

9 Application Questionnaire

Approvals

- Standard Version
 Intrinsically Safe Version (Exia IIC T6)
 Intrinsically Safe Version (Exia IIC T6)
 Intrinsically Safe Version+Ship Approval (Exia IIC T6)
 Intrinsically Safe Version+Explosion Proof (Exd [ia] IIC T6)

Measured Medium

Name _____
 Condition
 Liquid
 Solid (Form
 Mass
 Particle
 Dust)
 Temperature: Min. _____ C Norm. _____ C Max. _____ C
 Surface Flat Turbulent Agitated Vorte
 Dielectric Constant $\epsilon_r < 3$ $\epsilon_r > 3$

Atmosphere

Atmosphere Form Foam Dust Deposit Vapour
 Atmosphere Pressure Min. _____ Norm. _____ Max. _____

Vessel

Shape of Top Flat Arch Conical Horizontal
 Height _____ Diameter _____
 Critical Information
 Nozzle Length: _____ Nozzle Diameter: _____ Measurement Range: _____

Process Connection

Thread (G $\frac{3}{4}$ A $\frac{3}{4}$ NPT G1A G1A, M105x2 G1 $\frac{1}{2}$ A 1 $\frac{1}{2}$ NPT G2A)
 Flange (DN=) Swivelling Holder

Installation

Mode: Top Side
 Filling Stream inlet position and installation position (Please specify in the diagram below)

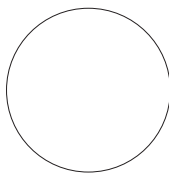

Circular Vessel

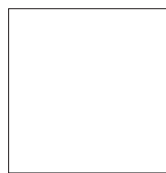

Square Vessel

Power Supply 220V AC 2-wire 24V DC 3-wire 24V DC 4-wire 24V DC

Communication (4~20) mA/HART

Display Yes No

Customer Information

Contact: _____
 Company: _____
 Address: _____
 P. C.: _____ Tel: _____
 Email: _____ Fax: _____

Please give brief explanation on the application of instrument:

Date:

Level Measurement Expert

Prisma Instruments
Expertise & Industrial Solutions

Prisma Instruments
89, rue du Vallat
13400 Aubagne
FRANCE

Tel. : +33 (0)4 42 70 74 04
Fax : +33 (0)4 42 70 38 64
@ : contact@prisma-instruments.com